

CALIBER



RMD 801DAB-BT MANUAL ENGLISH

Owner's Manual

*Deckless Video Player with AM/FM Receiver
Double-Din Mounting Chassis & Built-in TFT Display*

CONTENTS

Safety Precautions.....	2-3
Installation.....	4-5
Wiring Connections.....	6-7
Basic Operation.....	8-9
Radio Operation.....	10-11
Bluetooth Operation.....	12-13
USB/SD Operation.....	14
Steering Wheel Control.....	15
Other Operations.....	16
Maintenance.....	17
Infra Red Remote Control.....	18
Simple Troubleshooting Guide.....	19
Specifications.....	20

SAFETY PRECAUTIONS

- ⚠ **Important Warnings to Take Note of BEFORE Commencing Installation**
- ⚠ **Damage Caused By Incorrect Installation or Usage is NOT Covered By Warranty.**
PLEASE Take the Time to Read the Installation Notes Carefully.
- ⚠ **To Validate the Warranty Please Ensure That the Unit is Installed by a Professional, VAT registered Car Audio Installation Company.**
- **To avoid short in your vehicles electrical system, be sure to disconnect the battery cable before beginning installation.**
- The unit is intended for vehicles with a 12-volt battery and negative grounding. Before installing the unit in a recreational vehicle, truck, or bus, check that the battery voltage is 12 volts.
- **Remove the two transport screws from the top of the unit before installation.**
- **The black lead is ground.** A good chassis ground requires a tight connection to ground. The area should be free from rust, paint or any form of dirt. Please ground this lead separately from the ground of high-current products such as power amps. If you ground the products together and the ground becomes detached, there is a risk of damage to the products or fire.
Be sure to connect the colour coded leads according to the diagram. Incorrect connections may cause the unit to malfunction or
- damage the vehicle's electrical system. Cords for this product and those for other products may be different colours even if they have the same function. When connecting this product to another product, refer to the supplied installation manuals of both products and connect cords that have the same function.
Be sure to connect the negative (-) speaker leads to the negative (-) speaker terminal. Never connect the negative (-) speaker leads
- to chassis ground.
This unit is only designed for use with 4 speakers. Do not combine outputs for use with 2 speakers. Do not ground negative speaker leads to the chassis ground.
- Speakers connected to this unit must be high-power units with a minimum rating of 45W and impedance of 4 to 8 ohms. Connecting speakers with output and/or impedance values other than those noted there will result in damage to the head unit and the speakers.
- **Check the condition of your speakers carefully - connecting the unit to old or degraded speakers may result in a fault which will damage the audio IC and invalidate the warranty.**
If this unit is installed in a vehicle that does not have an ACC (accessory) position on the ignition switch, the red lead of the unit should be connected to a terminal coupled with ignition switch ON/OFF operations. If this is not done, the vehicle battery may be drained when you are away from the vehicle for several hours.

SAFETY PRECAUTIONS

- Secure the wiring with cable clamps or adhesive tape. To protect the wiring, wrap adhesive tape around them where they lie against metal parts. To avoid short-circuiting, cover all disconnected lead with insulating tape. There is a possibility of short-circuiting if the leads are not insulated.
 - Route and secure all wiring so it cannot touch any moving parts, such as the gear lever and handbrake. Do not route wiring in places that get hot, such as near the heater outlet. If the insulation of the wiring melts or gets torn, there is a danger of the wiring short circuiting to the vehicle's body.
 - Don't pass the yellow lead through a hole into the engine compartment to connect to the battery. This will damage the lead's insulation and cause a very dangerous short.
 - Do not shorten any leads, if you do, the protection circuit may fail to work when it should.
 - Never feed power to other equipment by cutting the insulation of the power supply lead of the unit and tapping into the lead. The current capacity of the lead will be exceeded, causing overheating.
 - Since a unique audio I/C circuit is employed, never wire so the speaker leads are directly grounded or the left and right - speaker leads are common.
 - When this product's source is switched ON, a control signal is outputted through the orange lead. Connect to an external power amp's system remote control or the car's Auto-antenna relay control terminal (max. 300mA 12V DC). If the car features a glass antenna, connect to the antenna booster power supply terminal.
 - When an external power amp is being used with this system, do not connect the orange lead to the amp's power terminal. Such connection could cause excessive current drain and a major malfunction. Refer to the relevant owner's manual for details on connecting the power amp and other units, then make the connections correctly.
 - Do not block any vents or heater panels, Blocking them will cause heat to build up and may result in fire.
 - Make sure that the unit has a good chassis ground. A good ground connection will eliminate most electrical noise. A good chassis ground requires a tight connection to the vehicles metal chassis. The area around the ground connection should be clean, bare metal without rust, paint, plastic or dirt for a good electrical connection.
 - If noise is still experienced when the motor of the vehicle accelerates, a choke should be placed in line with the power to the unit. The installation company will know what is required.
 - When replacing the fuse(s) the replacement must be of the same amperage as shown on the fuse holder. Never replace a fuse with another of a different value. If the fuse blows again please contact your installation company.
 - Double check that all wiring and connections are correct before re-connecting the battery and turning on the unit.
 - After completing the installation and before operating the unit, reconnect the battery, then press the (RES) button with a pointed object, such as a ball-point pen to set to unit to it's initial status. After pushing the button, wait a few seconds for the red light to flash.
-

INSTALLATION

Tools for Installation

Use the 2 removal wrenches of the old unit to take out the old unit and place with this brand new car radio. The following tools and supplies may also be needed for the installation:

Tools for Installation: Philips Screw-drivers /Machine Screws /Wire Stripper /Wire Cutter /Hammer /Pencil /Electrical Tape /Electric Drill

Supplies for Installation: Machine Screws /Crimp Connectors /14 Gauge Wire for Power Connections /14-16 Gauge Speaker Wires

The above are not supplied.

Before you install

Automotive audio equipment installations can be challenging even to the most experienced of installation technicians. We strongly recommend that this unit should be professionally installed by a VAT registered installer (this is a requirement to validate the warranty).

IMPORTANT: Remove the two transport screws from the top of the unit before installing.

Remove the Old Unit from the Dashboard

1. Remove the outer trim frame.

DIN Front Mount

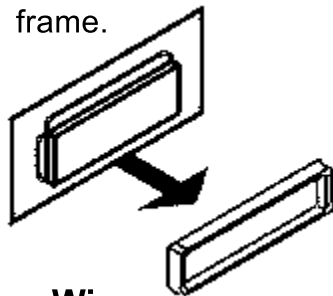

2. Insert the keys supplied with the old unit into both sides of the unit as shown in figure below until they click. Pull to remove the old unit from the dashboard.

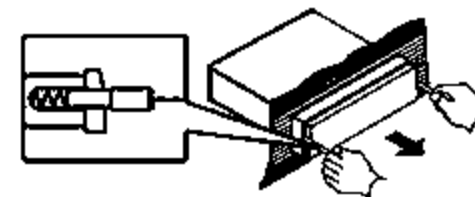

DO NOT DISCONNECT WIRES AT THIS TIME!

Mark Polarity of the Speaker Wires

Marking the polarity of the speaker wires will make it easier to connect the existing speakers to your car radio. Consult wiring diagram of existing head unit before disconnecting any wires. If you are not positive of the polarity of the existing wires from the speakers to the head unit, install new wires.

1. While the old unit is playing, disconnect the wires from one speaker.
 2. Take a length of masking tape and fold it around the wire so it forms a flag.
 3. On the masking tape mark the polarity of the speaker wires (+&-), as well as left or right, and front or rear.
 4. Double check that you marked the first speaker correctly by checking that the speaker wires are the same at the head unit.
 5. Repeat this procedure for all of the speakers.
 6. Mark the power, ground, and any other wires also.
-

INSTALLATION

WARNING: Disconnect negative battery terminal from battery before starting installation. Consult the vehicle's owner's manual for proper instructions.

NOTE: Mark the polarity of the existing speaker wires before disconnecting battery.

NOTE: Remove the two transport screws from the top of the unit before installing.

NOTE: Make sure there is enough space for the installation of this double-din unit.

SUPPLIED TOOLS

①	②	③	④	⑤
X2	X1	φ 5X12 X4	φ 5X6 X4	φ 5X20 X1
⑥	⑦	⑧	⑨	
				X2
X1	X2	X2	X1	

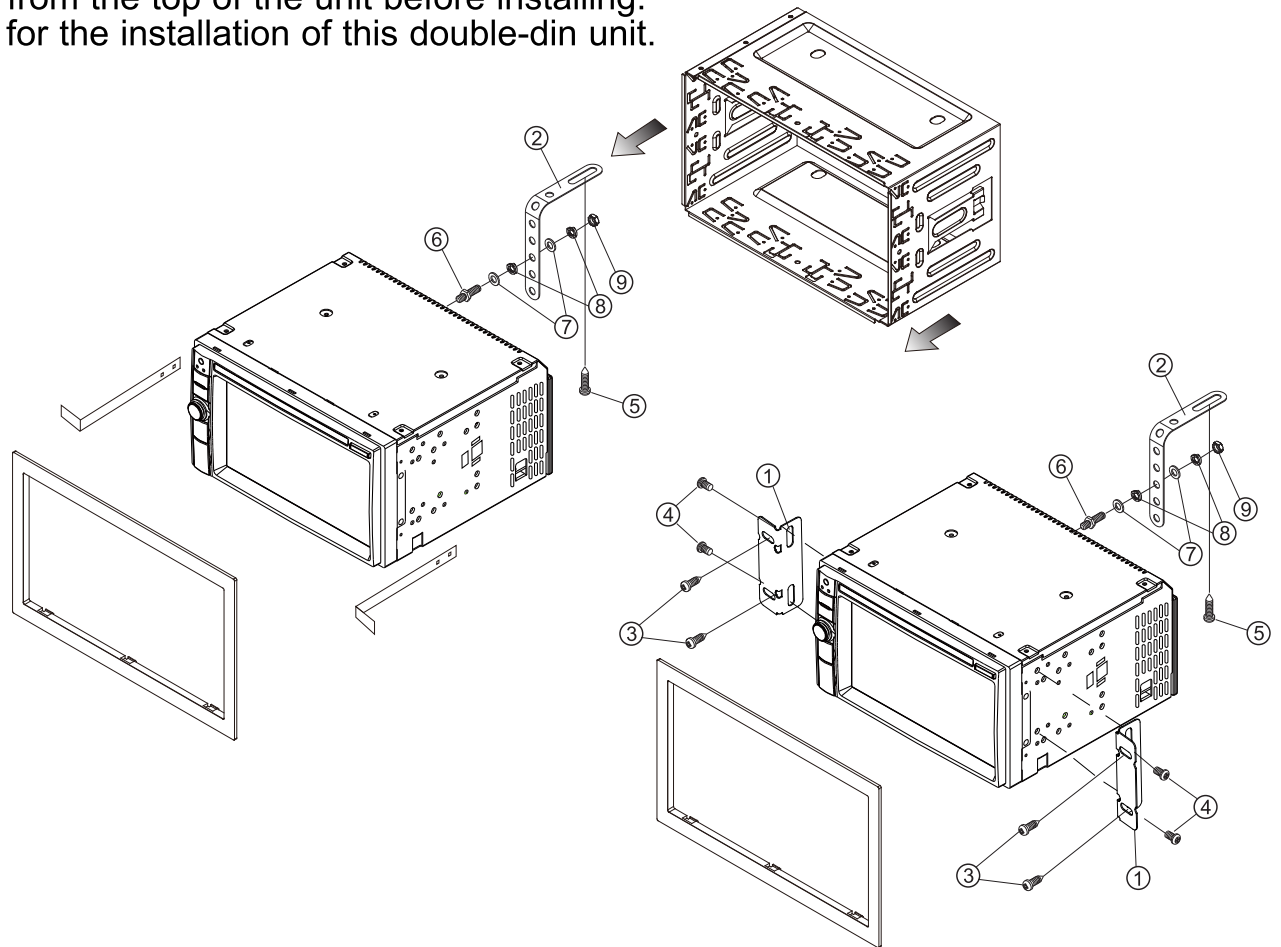

WIRING DIAGRAM

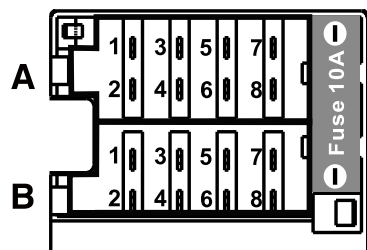
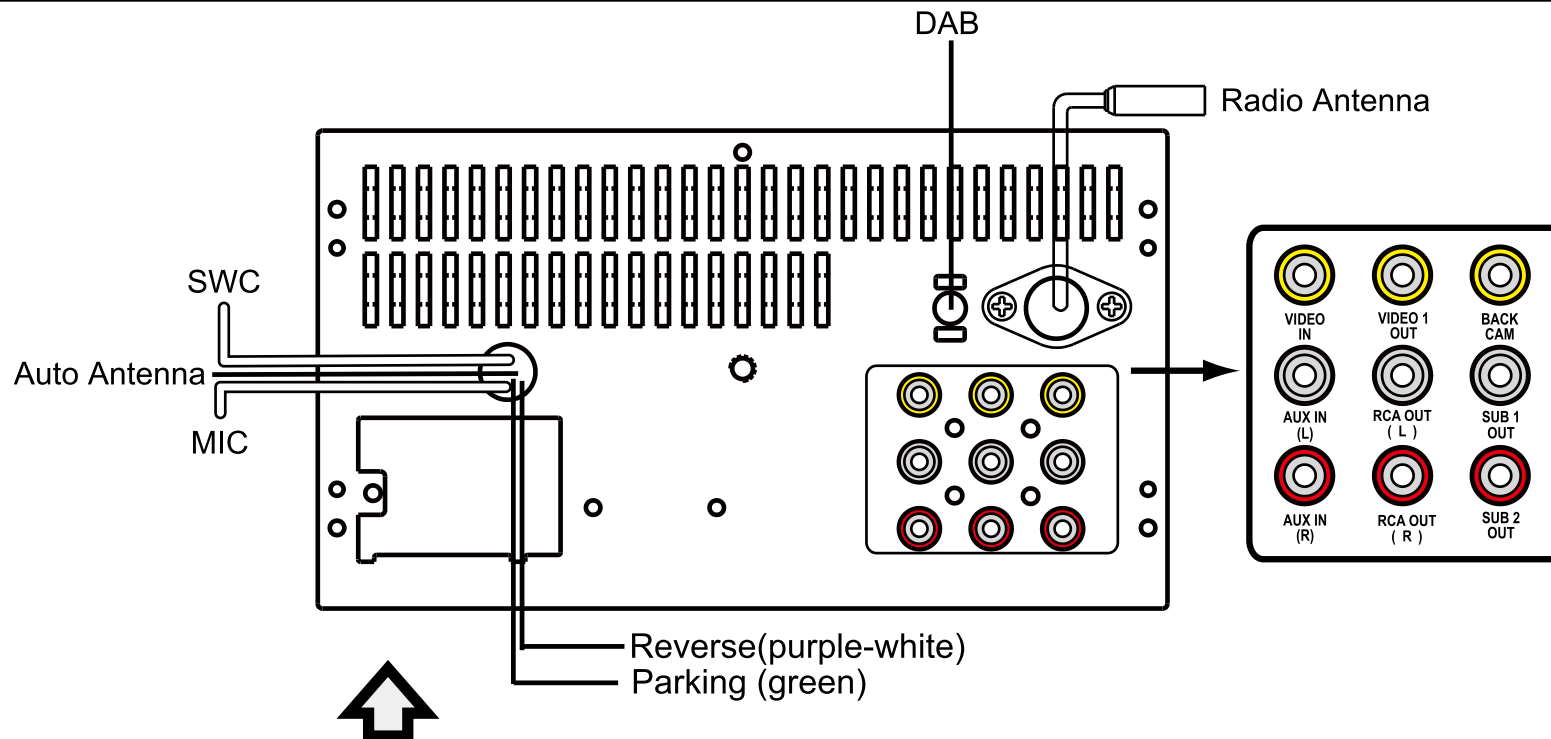

Connector A

- 1. Rear right speaker(+)/Purple
- 2. Rear right speaker(-)/Purple-Black
- 3. Front right speaker(+)/Grey
- 4. Front right speaker(-)/Grey-Black
- 5. Front left speaker(+)/White
- 6. Front left speaker(-)/White-Black
- 7. Rear left speaker(+)/Green
- 8. Rear left speaker(-)/Green-Black

Connector B

- 1. -
- 2. -
- 3. -
- 4. Battery 12V (+)/Yellow
- 5. Antenna power/Blue-White
- 6. Panel light/Orange-White(optional)
- 7. ACC+/Red
- 8. Ground/Black

WIRING DIAGRAM

General Wiring Notes:

Make sure You have a good chassis ground. Good ground connection will eliminate most electrical noise problems. A good chassis ground requires a tight connection to the .vehicle's metal chassis. The area around the ground connection should be clean, bare metal without rust, paint, plastic, dust, or dirt for a good ground connection.

Black Ground

Connect to vehicle body/chassis. Make sure you have a good chassis ground. This will eliminate most electrical noise form the motor and alternator. A good chassis ground requires a tight connection to ground. The area should be free from rust, paint or any form of dirt.

Red Ignition

Connect to car ignition switch for main power supply of the unit.

Yellow Memory Backup

Connect to electrical terminal always supplied with power regardless of ignition switch position.

Blue-White Remote

Connect to Auto-antenna or power amp control wire/remote connection. Maximum current 300mA 12VDC. (Low Current)

Green (Hand Brake - Ground)

Connect this wire to the hand brake wire of your car so that the display will be on only when the car is fully stopped.

Purple-White (Rear Gear - VCC)

Connect this wire to the rear gear wire of your car so that the backup camera function can be activated when you car is in reverse gear.

Orange-White (Panel Light)

Connect the this wire to the car light switch so that the front panel illumination will be on when the car light switch is turned on.

Various outputs (Refer to the wiring diagram)

Refer to the wiring diagram for the connection details.

Speaker Wiring Notes:

Follow the above wiring diagram to install the head unit with new or existing speakers.

1. This unit is designed for use with four (4) speakers with impedance between 4 Ohms to 8 Ohms.
 2. An Impedance load of less than 4 Ohms could damage the unit.
 3. Never bridge or combine the speaker wire outputs. When not using four speakers, use electrical tape to tape the ends of the unused speaker outputs to prevent a short circuit.
 4. Never ground the negative speaker terminals to chassis ground.
-

BASIC OPERATION

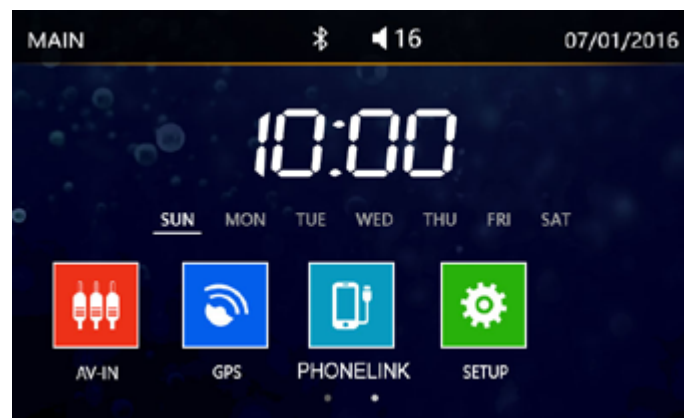
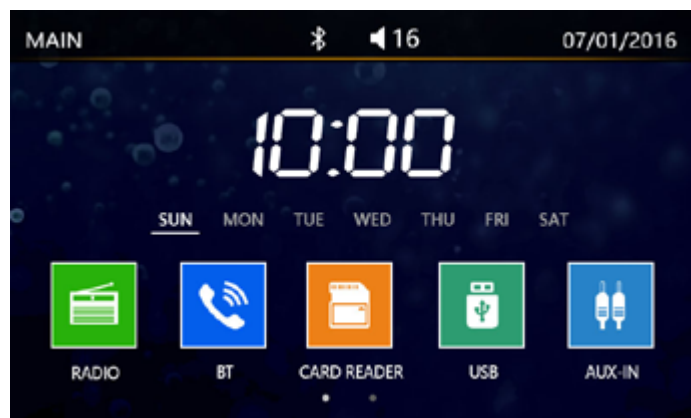

1. Turning the unit On / Off

Press the Power Button to turn the unit on. When the unit is on, press the Power Button once to turn the TFT off. During TFT off, the video out signal will be available so that the connected monitor will show the screen of the unit. Press the Power Button again to turn the TFT back on. Press and hold the POW button again to turn the unit off.

2. Sound Control

A. Volume

Use the VOL +/- Button to adjust the volume level. Turn the button clockwise to increase the volume, and vice versa. The larger the number of volume, the higher the volume level. You can also adjust the volume by sliding the volume icon on top of the screen.

B. Bass

Press the SEL Button until the display shows "BAS". Use the VOL +/- Button to adjust. When EQ is ON, bass control is not available.

C. Treble

Press SEL Button until the display shows "TRE". Use the VOL +/- Button to adjust. When EQ is ON, treble control is not available.

D. Balance

Press SEL Button until the display shows "BAL", then use the VOL +/- Button to adjust the balance between the left & right speakers.

E. Fader

Press SEL Button until the display shows "FAD", then use the VOL +/- Button to adjust the balance between the front & rear speakers.

F. Other Audio Settings

You can adjust other audio settings like preset equalizer, loudness or subwoofer ON/OFF by tapping the "EQ" icon on the main menu, or on the control menu of other audio/video play modes.

BASIC OPERATION

3. HOME Button

- In Radio and Aux modes, press the HOME button to go back to the home screen.
- In USB and SD modes, during music or video playback, press the HOME button once to go back to the directory page, in which you can choose the desired file by pressing and turning the volume knob. Press again the HOME button to go back to the home screen.

4. Day Light Saving

Tap the Day button on the OSD to increase brightness. Tap again to reduce brightness during night time. Tap again for black out the screen.

5. SETUP

Enter the setup menu in the home screen by tapping the "SETTING" icon on the main menu. Tap the items you would like to set. You can select Language, adjust Audio, Date and Time, Radio Area, Wheel Controls, Display, Wallpaper and other settings.

Radio Operation



1. Choose Radio Band

In radio mode, touch the BAND button onscreen to choose among the five radio bands - three FM Bands (FM1, FM2, and FM3) and two AM Bands (AM1, and AM2). Each of the five bands can store up to six preset stations, for a total of 30 preset memory stations.

2. Radio Seek Function

In Radio Mode, touch >| or |< icon to adjust the radio frequency automatically. Touch the > or < button once to adjust the radio frequency manually.

3. Save Your Preset Stations

There are six numbered preset buttons on the the screen (P1-P6) which can store and recall stations for each band. While listening to a radio station you would like to save as a preset, touch and hold any key from P1-P6 until you hear a beep. The station will be saved in the designated number.

4. Mono/Stereo Reception Control

In FM radio mode, touch the ST button to select stereo or mono reception.

5. Local/Distance Reception Control

In radio mode, touch the LOC button to select local or distance reception.

Radio Operation

6. RDS Control (Optional)

AF, TA, PTY are the RDS functions. They are applicable to certain countries only. For countries when RDS is not available. The touch sensitivity of the button will be disabled.

7. Returning to Main User Interface

Touch the “BACK” sign or HOME button in the top right hand corner to return to the main user interface.

Bluetooth Operation

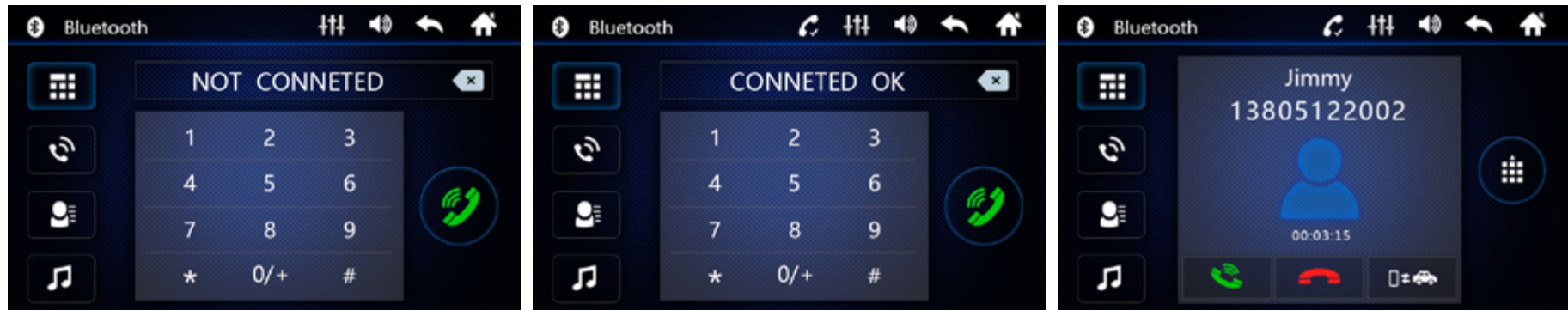

PAIRING

At BT mode, search bluetooth device by the phone and “BT Car stereo” will appear in your phone. Just touch it to establish connection, and connected OK will appear on the screen.

DIAL PAD

Touch the dial pad to dial the number you would like to call. Touch the CALL (green) button to send the number.

REJECT CALL

Press the REJECT (red) button to end the call or to reject an incoming call.

CALL RECORD

Press the HISTORY button to enter the phone book page to view received, missed and dialed calls. Move the scroll bar on right hand up or down to view more received, missed and dialed calls.

A2DP

Press the MUSIC button to enter the A2DP page to control playing music of your cellphone.

RETURN TO USER MANUAL

Touch the “back arrow” key or HOME key on the top right corner to return to the main user interface.

Bluetooth Operation

View Received Calls

Touch the RECEIVED CALLS button, the recent 6 received calls will be displayed. There will be up/down scroll bar for you to view all the received calls one by one.

View Missed Calls

Touch the MISSED CALLS button, the recent 6 missed calls will be displayed. There will be up/down scroll bar for you to view all the missed calls one by one.

View Dialed Calls

Touch the DIALED CALLS button, the recent 6 dialed calls will be displayed. There will be up/down scroll bar for you to view all the dialed calls one by one.

Playing Music on your cellphone

After activating music player in the cellphone and selecting "Play via bluetooth", touch ► to play or pause the music. Touch |◀ and ▶| to select down or up one song in your song list.

USB/SD Operation

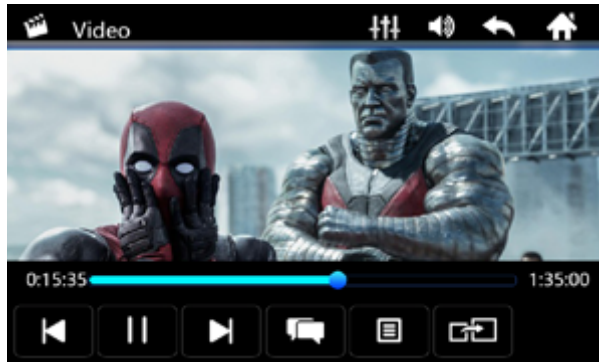



Plug the USB/SD card into the USB/SD port. The unit will play the contents automatically.

1. Advance / Go Back

Advance to the next track or go back to the previous track by touching the forward or rewind buttons on screen.

2. Music Playback Mode

When play music, touch the  icon to play randomly and touch once again to resume. Touch  button to cycle the song you are listening and touch once again to resume.

3. Play/Pause

Press the play/pause button to pause the playback or resume.

4. HOME button

Press the HOME or BACK button during playback in order to see the full list of files along with file types. All the file names are displayed for your easy reference. Select the desired file types and file names by tapping on the screen.

Steering Wheel Control

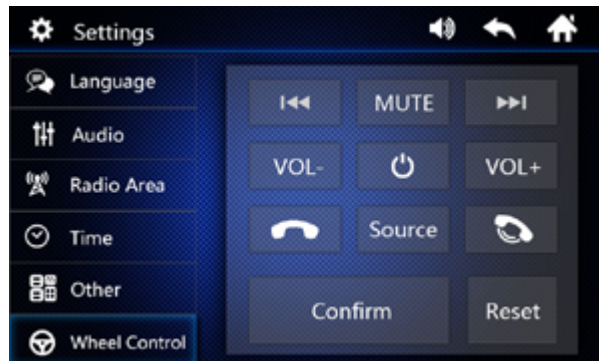

Refer to the wiring diagram for connection. The brown wire (Steering 1) must be connected, then the white or grey (Steering 2A and 2B) will be connected depending on the total number of the wire from the steering wheel remote control of your vehicle.

TAB STEERING WHEEL LOGO in the OSD. Press RESET before the set up. Select from the 10 functions according to the number of available keys on the steering wheel of your vehicle. Press any key on your steering wheel, then tab the function key you would like to assign. The frequency of the function will be shown on the display. Repeat the step for other keys on the steering wheel. Tab ENTER after your set up is complete and then you can operate the unit by your steering wheel.

Other Operations

1. DAB Control

This unit can support DAB receiver. If DAB control is available with the system, tap the DAB logo on the OSD to enter DAB mode. Follow professional advise for antenna installation.

2. AV Input

The AV Input Jack is a set of composite input on the rear of the unit. Connect any portable audio/video device such as a DVD player or VCD player to unit. Use the volume control to adjust volume.

3. Backup Camera Input

The backup camera input is on the back of the unit. (refer to wiring diagram). This input (in yellow) is for connecting backup camera for parking. You must connect the VCC wire (in pink color) to the reverse gear switch in order to activate this video input mode when you switch the reverse gear of your car. Please refer to the wiring diagram for more details.

4. Video OutputX2

The Video Output Jack is on the back of the unit. (Refer to Wiring Diagram) This output (in yellow) is for connecting monitor(s). You must connect a monitor for car in order to play this unit in another monitor. Consult your dealer for any kinds of monitors that are suitable to use in car.

5. RCA OutputX2

The RCA Output Jack is on the back of the unit. (Refer to Wiring Diagram) This output is for connecting amplifier, equalizer, or other audio component that requires a pre-amp out connection. (Red=Right, White=Left) Follow the manufactures instructions for the audio component that you are connecting.

6. Subwoofer Output x 2

The Subwoofer Output Jack is on the output wire harness. (Refer to Wiring Diagram) This output is for connecting up to 2 subwoofer amplifier to the Subwoofer Output Jack to drive a subwoofer. Follow the amplifier's installation instructions. Press and hold the BND/NP/SUB button to activate or deactivate this function.

MAINTENANCE

Cleaning the Unit

Do not use any liquids to clean this unit.
Do not use petroleum distillates to clean this unit.
Use a clean, dry cloth to clean this unit.

Replacing the Fuse

Make sure the amperage matches the specified value when replacing the fuse(s). If the fuse is bad, check the power connection and replace the fuse with a new one. If the same problem occurs, this might indicate a malfunction within the unit.

Warning

When replacing a fuse, do not use a fuse with a higher amperage rating than the fuse originally supplied to your unit, otherwise damage will result to your unit.

Infra Red Remote Control (Optional)

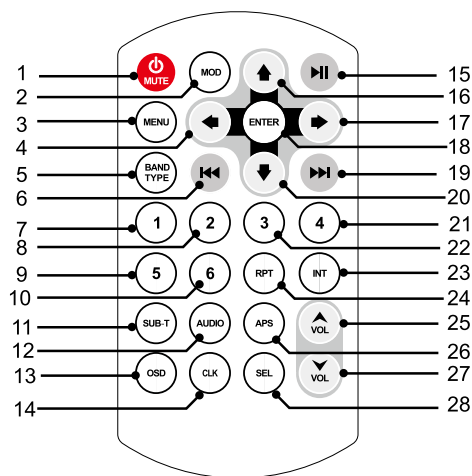

1. Power On/off/mute
2. Mode Select Key
3. MENU Button
4. Navigation Left
5. Band/Select Type
6. Previous Track/Previous Radio Station
7. Number 1
8. Number 2
9. Number 5
10. Number 6
11. Subtitle Language Switching Key
12. Change The Audio Output Method
13. Statistical Disc Information Display Button
14. Time Clock Display
15. Play/Pause Function
16. Navigation Up
17. Navigation Right
18. Confirm The Track/Chapter Sele or Select Item In SETUP Menu.
19. Next Track/Next Radio Station
20. Navigation Down
21. Number 4
22. Number 3
23. Intro
24. Repeat Play
25. VOL+
26. Auto Preset Scan
27. VOL-
28. Sound Select Key

This unit comes with a full remote control system. The CR-2025 Lithium battery is an included item with the remote control. TO PLACE THE BATTERY:

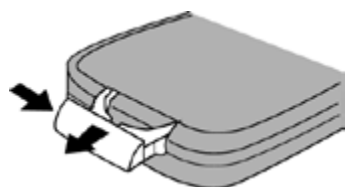

(1) Remove the cover from the back of the remote control.

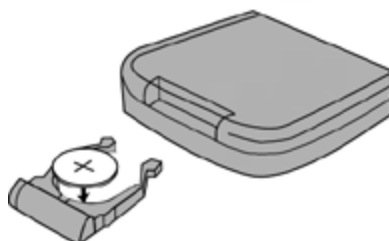

(2) Insert a CR-2025 Lithium battery.

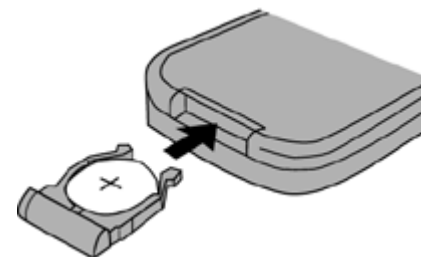

(3) Insert the battery holder into the back of the remote control.

Operating the remote control

Aim at the face panel of the CD Receiver, the maximum distance at which signals can be received is about 6M. Make sure that the signal path is not obstructed. Do not drop or throw the remote control. Do not place the remote control in a location that is exposed to direct sunlight or next to a heating unit or other heat source.

SIMPLE TROUBLESHOOTING GUIDE

PROBLEM	CAUSE / SOLUTION
No Power	Check whether the fuse is blown, replace with fuse of proper value if necessary.
Unit stops responding or shows error in display	Press the RESET button.
Unable to receive radio stations	Check whether the antenna is inserted or the antenna is properly connected; if not, insert the antenna or connect it properly.
Poor effect on receiving a station	<ul style="list-style-type: none">-Antenna may not be of the proper length. Make sure the antenna is fully extended. If broken, replace the antenna with a new one.-The broadcasting signal is weak.-The antenna is poorly grounded; check and make sure the antenna is properly grounded at its mounting location.
No pictures	<ul style="list-style-type: none">-The video line from main unit to monitor is not connected properly. (for external monitor)-The purple brake wire is not grounded or connected to brake properly.
The picture appears grainy	<ul style="list-style-type: none">-Check the color system. (PAL or NTSC)-The disc is dirty or damaged.

Specifications

GENERAL

Operating Power.....12 Volts DC, Negative Ground
Output Wiring.....Designed for using four speakers only
RCA line out.....low-level outputs - 1000mV
Output Impedance.....Compatible 4 to 8 Ohm Speakers
Fuses.....10 amp
Dimensions.....178mm(W) x 150mm(D) x 100mm (H)
Weight.....2.0 Kg

TFT/SYSTEM

Resolution.....800RGB(H)X480(V)
Brightness/Contrast.....400cd/m²/600
Viewing angle.....70
Response Time.....Tr-2s/Tf-6s
Dimension.....6.5"
AspectRatio.....16:9

FM/TUNER

Tuning Range..... (USA) - 87.5 - 107.9MHz, (Europe) - 87.5 - 108 MHz
FM Sensitivity.....12dBu
Stereo Separation @ 1 Khz.....35dB

AM/TUNER

Tuning Range..... (USA) - 530 - 1710 KHz, (Europe) - 522 - 1620 KHz
Am Sensitivity.....30dBu

WWW.CALIBEREUROPE.COM

CALIBER HEAD OFFICE · The Netherlands · Fax: +31 (0)416 69 90 01 · E-mail: info@caliber.nl