

RMD 021

Manual

GB

User's Manual

Car Audio Player

I. Control Panel

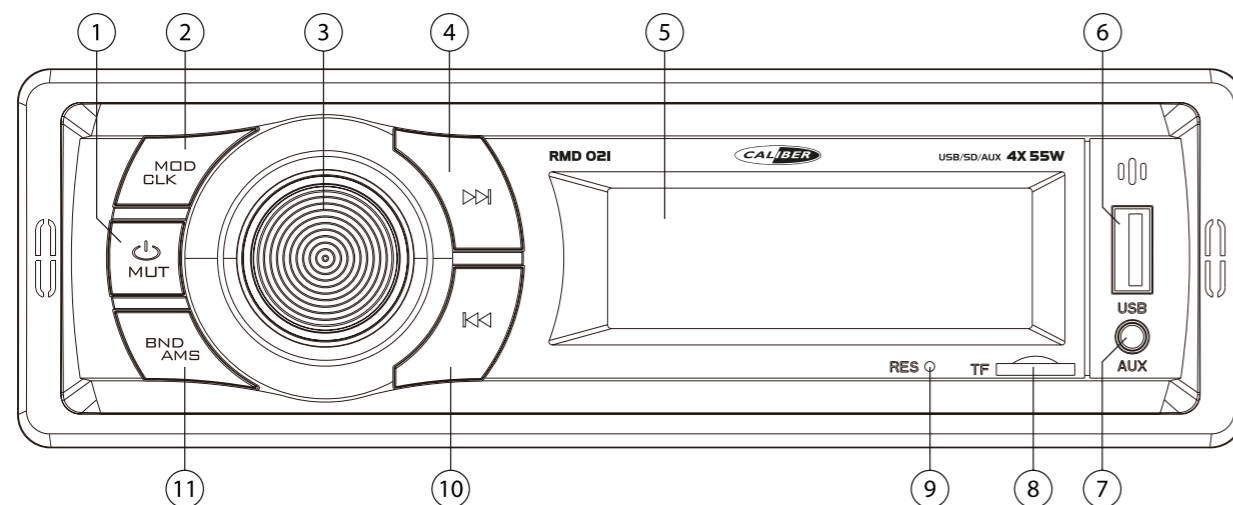

- | | |
|---|---|
| 1. Power switch/Mute/Pause | 8. MicroSD card slot |
| 2. Mode switching/Clock button | 9. Reset button |
| 3. Volume control/Function selection | 10. Previous track/Search radio station backwards |
| 4. Next track/Search radio station forwards | 11. Band switching/Automatic memory storage |
| 5. Display | |
| 6. USB interface (No charge function) | |
| 7. AUX-IN jack | |

II. Basic operations

1. Power switch/mute/pause button (⏻)
 - a) Short press “⏻” button in the standby state and the radio will be started up; long press “⏻” in the ON state and the radio will be shut down.
 - b) Short press this button in the radio or AUX state, and it is the “Mute” function. Short press this button when the MP3 is being played, and it is the “Pause/Play” function.
2. Mode switching/clock button (MOD/CLK)
 - a) Short press this button to switch the mode (Radio/USB/SD/AUX).
 - b) Long press this button to display the clock which will automatically exit after 3 sec. When the clock is displayed, long press this button for 2 sec. to adjust the hour: the digit will flicker, and rotate the volume knob to adjust the time; short press this button again to adjust the minute: the digit will flicker, and rotate the volume knob to adjust the time. 5 sec. after completion of the operation, the system will automatically confirm the time and return to the state before entering the clock adjustment.
3. Volume control/function selection button
 - a) Adjust this button clockwise to increase the volume and counterclockwise to reduce the volume in the radio/playback state.
 - b) Short press this button in the radio/playback state to enter function of BASS, TER (treble), BAL (balance), FAD (fader), EQ (equalizer), LOUD ALL (loudness), DX/LOC (distant/local), STEREO/MONO (stereo radio/force mono), CH/STEP (choose radio station/stepped frequency), CLOCK24/12 (24/12-hour clock), or AREA EU/US (European standard/American standard), and adjust the volume knob to select the corresponding function.
4. Next track/search radio station forwards
 - a) In the radio state, short press this button to select next radio station, and long press this button to semi-automatically search the radio stations forwards.
 - b) In the MP3 playback state, short press this button to select the next song, and long press this button to fast forward the song.
5. Display

It displays the radio frequency and current playback information.
6. USB interface (USB)

Insert a USB flash drive, and it will automatically play the song in the corresponding format.
7. Built-in microphone

Built-in microphone for handsfree calling
8. AUX-IN jack (AUX)

It is used for connecting external audio signal.
9. MicroSD card slot / TF card slot (TF)

Insert a MicroSD card, and it will automatically play the song in the corresponding format.
10. Reset button (RES)

Short press this button to conduct system resetting when the radio system functions in disorder. The radio shall be restarted for operation after the resetting.
11. Previous track/search radio station backwards
 - a) In the radio state, short press this button to select previous radio station, and long press this button to semi-automatically search the radio stations backwards.
 - b) In the MP3 playback state, short press this button to select the previous song, and long press this button to fast backward the song.
12. Band switching/automatic station locking (BND/AMS)

In the radio state, short press this button to switch the band (FM1-FM2-FM3), and long press this button to automatically search the radio stations and store the searched stations in P1-P6 in order; after the automatic search, the radio station stored in P1 will be automatically played. 6 radio stations can be stored in each band, and 18 radio stations in total can be stored.

III. Operating Instructions for Station Adjustment

Manual step-by-step station adjustment

In the radio state, short press "SEL" button for many times to enter the "CH" (choose radio station) state, and adjust the volume knob to enter "STEP" (stepped frequency) state. And then short press "▶▶" or "◀◀" to adjust the station step by step, and the system will automatically return to "CH" state after 5 sec. without operation.

V. Installation Drawing

1. Before installing the radio, place the radio according to the assembly position, and connect the corresponding speaker line and power line for listening test.
2. Fix the radio only after its running effect is ideal.

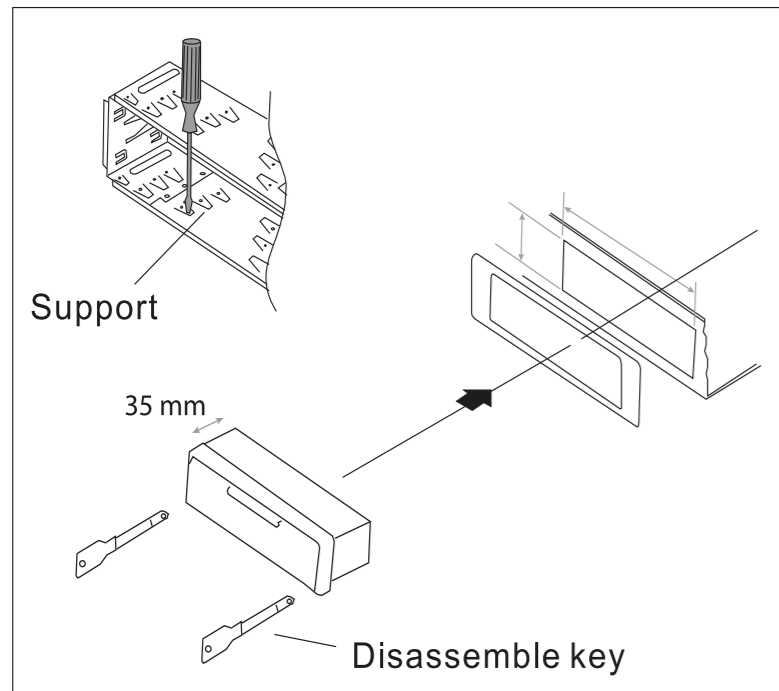

■ Install the radio

1. Install the support on the dashboard, and bend its partial parts for sticking in the positions.
2. Connect the power line and speaker line, and fix the fixing plate on the car.
3. Insert the antenna plug and push the radio into the support, and tighten fixing screws of the fixing plate.

■ Disassemble the radio

Insert both of the tool for disassembling radio into the gaps on left and right sides to make them hook the radio, and then gently pull out the tools to make the radio separated from the support. Then disassemble the connecting lines and unplug the antenna plug.

VI. Wiring Diagram

ISO connector:

- B1. Rear right speaker(+) / Purple
- B2. Rear right speaker(-) / Purple-Black
- B3. Front right speaker(+) / Grey
- B4. Front right speaker(-) / Grey-Black
- B5. Front left speaker(+) / White
- B6. Front left speaker(-) / White-Black
- B7. Rear left speaker(+) / Green
- B8. Rear left speaker(-) / Green-Black

- A1. Not connected
- A2. Not connected
- A3. Not connected
- A4. Battery 12V (+) / Yellow
- A5. Antenna power / Blue-White
- A6. Not connected
- A7. ACC+ / Red
- A8. Ground / Black

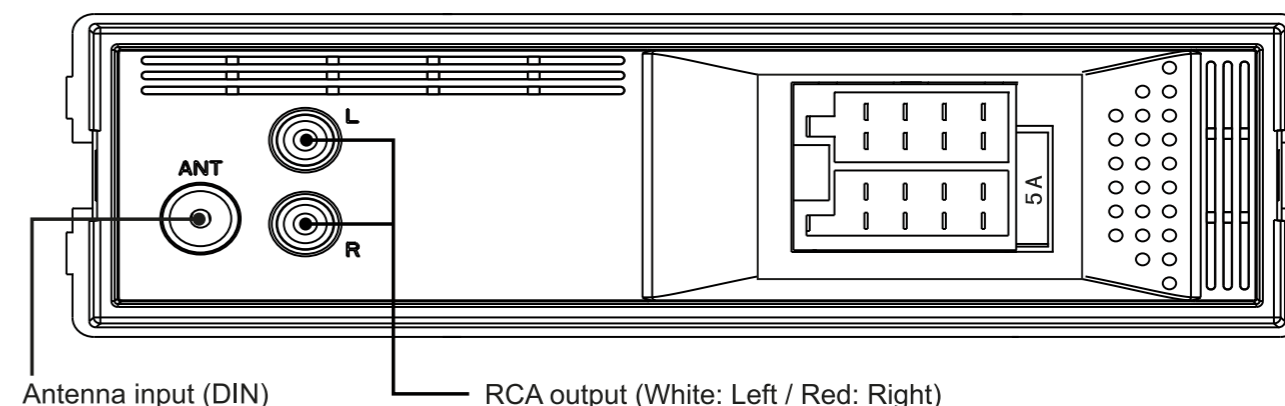
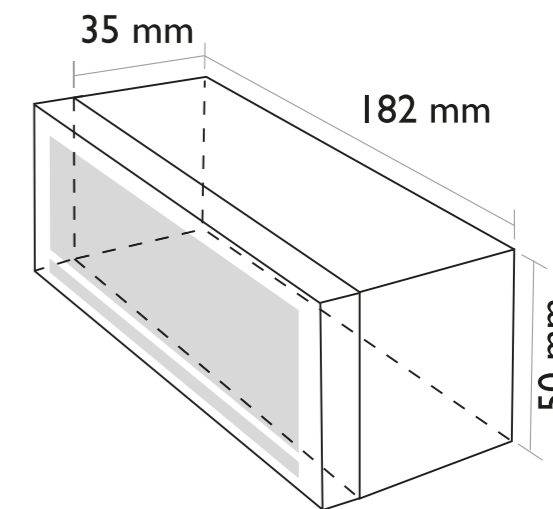
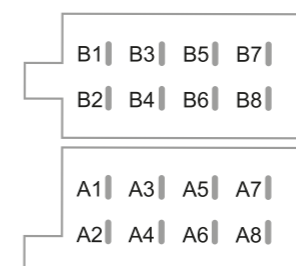

Warning: The negative speaker lead should NOT be grounded, otherwise it will damage the radio!

WARNING!

To connect the unit, use ISO connectors only.
If your vehicle isn't equipped with an ISO connector, please use the provided ISO loom cable. This prevents an incorrect wired connection.

Damage caused by faulty wiring: warranty will be void.

- GB** Caliber hereby declares that the item RMD 021 is in compliance with the essential requirements and other relevant provisions of Directive 2014/53/EU (RED), 2011/65/EU (RoHS), 2014/30/EU (EMC) and 2014/35/EU (LVD).
- FR** Par la présente Caliber déclare que l'Appareil RMD 021 est conforme aux exigences essentielles et aux autres dispositions pertinentes de la directive 2014/53/EU (RED), 2011/65/EU (RoHS), 2014/30/EU (EMC) et 2014/35/EU (LVD).
- DE** Hiermit erklärt Caliber, dass sich das Gerät RMD 021 in Übereinstimmung mit den grundlegenden Anforderung und übrigen einschlägigen Bestimmungen der Richtlinie 2014/53/EU (RED), 2011/65/EU (RoHS), 2014/30/EU (EMC) und 2014/35/EU (LVD) befindet.
- IT** Con la presente Caliber dichiara che questo RMD 021 è conforme ai requisiti essenziali ed alle altre disposizioni pertinenti stabilite dalla direttiva 2014/53/EU (RED), 2011/65/EU (RoHS), 2014/30/EU (EMC) e 2014/35/EU (LVD).
- ES** Por medio de la presente Caliber declara que el RMD 021 cumple con los requisitos esenciales y otras disposiciones Aplicables o exigibles de la Directiva 2014/53/EU (RED), 2011/65/EU (RoHS), 2014/30/EU (EMC) e 2014/35/EU (LVD).
- PT** Caliber declara que este RMD 021 está conforme com os requisitos essenciais e outras disposições da Directiva 2014/53/EU (RED), 2011/65/EU (RoHS), 2014/30/EU (EMC) e 2014/35/EU (LVD).
- S** Härmed intygar Caliber att denna RMD 021 Pro står i överensstämmelse med de väsentliga egenskapskrav och övriga relevanta bestämmelser som framgår av direktiv 2014/53/EU (RED), 2011/65/EU (RoHS), 2014/30/EU (EMC) sv 2014/35/EU (LVD).
- PL** Niniejszym Caliber oświadcza, że RMD 021 jest zgodne z zasadniczymi wymaganiami oraz innymi stosownymi postanowieniami Dyrektywy 2014/53/EU (RED), 2011/65/EU (RoHS), 2014/30/EU (EMC) i 2014/35/EU (LVD).
- DK** Undertegnede Caliber erklærer hermed, at følgende udstyr RMD 021 overholder de væsentlige krav og øvrige relevante krav i direktiv 2014/53/EU (RED), 2011/65/EU (RoHS), 2014/30/EU (EMC) og 2014/35/EU (LVD).
- EE** Käesolevaga kinnitab Caliber seadme RMD 021 vastavust direktiivi 2014/53/EU (RED), 2011/65/EU (RoHS), 2014/30/EU (EMC) põhinoetele ja nimetatud direktiivist tulenevatele teistele asjakohastele sätetele ja 2014/35/EU (LVD).
- LT** Šiuo Caliber deklaruoja, kad šis RMD 021 atitinka esminius reikalavimus ir kitas 2014/53/EU (RED), 2011/65/EU (RoHS), 2014/30/EU (EMC) Direktyvos nuostatas ir 2014/35/EU (LVD).
- FI** Caliber vakuuttaa täten että RMD 021 tyyppinen laite on direktiivin 2014/53/EU (RED), 2011/65/EU (RoHS), 2014/30/EU (EMC) oleellisten vaatimusten ja sitä koskevien direktiivin muiden ehto jen mukainen ja 2014/35/EU (LVD).
- IS** Hér með lýsi Caliber yfir því að RMD 021 erí samræmi við grunnkröfur og aðrar kröfur, sem gerðar eru í tilskipun 2014/53/EU (RED), 2011/65/EU (RoHS), 2014/30/EU (EMC) and 2014/35/EU (LVD).
- NO** Caliber erklærer herved at utstyret RMD 021 er i samsvar med de grunnleggende krav og øvrige relevante krav i drektiv 2014/53/EU (RED), 2011/65/EU (RoHS), 2014/30/EU (EMC) og 2014/35/EU (LVD).
- NL** Hierbij verklaart Caliber dat het toestel RMD 021 in overeenstemming is met de essentiële eisen en de andere relevante bepalingen van richtlijn 2014/53/EU (RED), 2011/65/EU (RoHS), 2014/30/EU (EMC) en 2014/35/EU (LVD).



Latest declaration form can be found at:
www.caliber.nl/media/forms/DeclarationRMD021.pdf

WWW.CALIBER.NL

CALIBER EUROPE BV • Kortakker 10 • 4264 AE Veen • The Netherlands